

TOP MOUNT MAGNETIC LEVEL GAUGE

MODEL NO: JMG/T/6C/TFS/41R/SF1G/F/S4/1642mm/2450mm

Welding Procedures
1-T-8
3-T-1/8

BILL OF MATERIALS	
ITEM #:	DESCRIPTION:
1	1" s/40 SA312 TP316/316L wld pipe
2	1" s/40 SA479 316/316L Flat Pipe Cap
3	4" 150# SA105 RFBF, B16.5 -Machined for Top Mount
4	3" s/10 SA312 TP316/316L smls pipe -stilling well
5	Float: 2-1/2" Gr2 Titanium
6	Standard MBG / ylw-blk / Glass tube -Ft-in ruler with 1/2" divisions
-	LMS200.N4.A1.Y0.A1 10A DPDT Point Level Switch -Ser. #: 1909007-06 -Tag #: LSH-1802

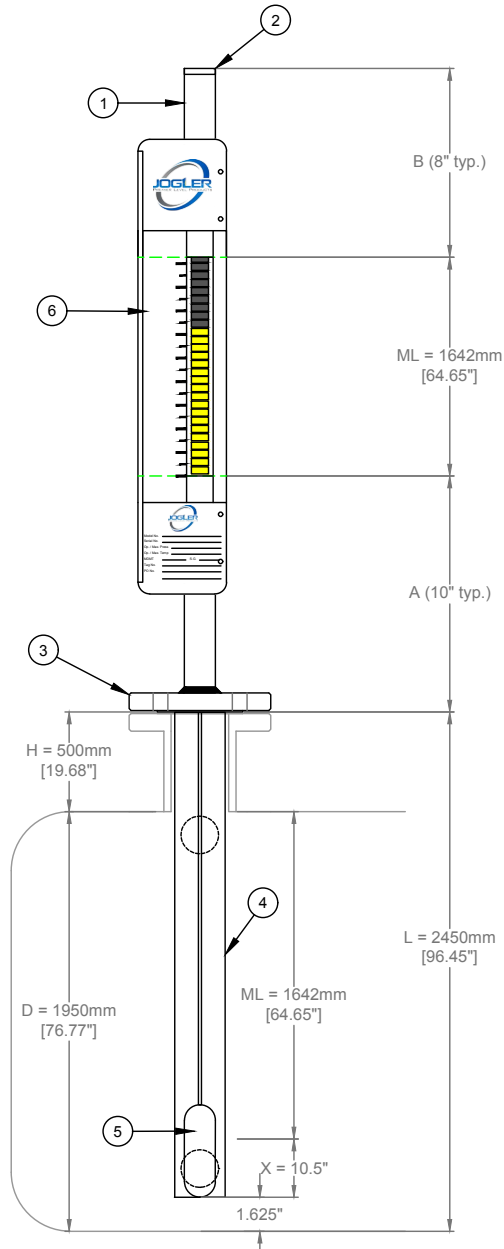

DOCUMENTATION / TESTING	
ITEM #:	DESCRIPTION:
1	Certified Approval Drawings
2	Material Test Reports -EN10204 Type 3.1

NOTES / ACCESSORIES	
NOTE:	DESCRIPTION:
Code	All design to ASME B31.3
Bolting	-5/8" x 3-1/2" SA193 Gr B7 studs -5/8" SA194 Gr 2H heavy hex nuts -cadmium yellow plated
Gasket	4" 150# Grafoil GHR Ring (1/16" Thick)

REVISION TABLE			
REV:	DESCRIPTION:	APPROVAL:	DATE:
0	Initial Revision	KAC	9/23/2019
1	Dimensional Revisions	KAC	10/14/2019

CUSTOMER:	INNOVATEK		
PROJECT:			
TAG NUMBER:	LG-1802	SN:	1909007-05
SG:	0.6 - 1.00		
OP/MAX TEMP:	- / 80 °F		
OP/MAX PRES:	- / ATM		
SERVICE:	N/A		
NOTES:			



6646 COMPLEX DRIVE
BATON ROUGE, LA 70809
TELEPHONE: 225.456.2495
TELEFAX: 281.469.0422
TOLL FREE: 800.223.8469
WEBSITE: WWW.JOGLER.COM
EMAIL: Inquiries@JOGLER.COM

QUOTE NUMBER:
190716T-JMG REV6
WORK ORDER:
1909007

NET WT.
TBD
APPROVED BY:

CUSTOMER PO NUMBER:
19200-068